

# Wire end sleeve insulated twin 0.75 mm<sup>2</sup> - 10 mm A00777TWIN

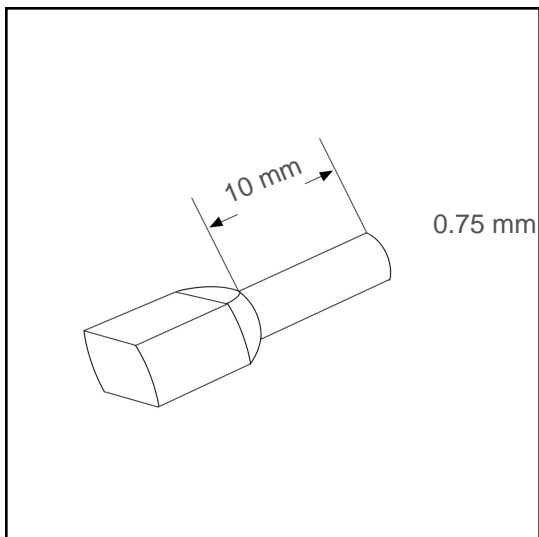

## Datasheet:

Cross section (mm <sup>2</sup> ):	0.75
AWG:	2x18
Length (mm):	10
Color:	white
Material:	Cu-DHP / Polypropylene
Surface:	tin plated
Minimum thickness of tin coating:	3 μm
Max. Temp:	105°C
REACH/RoHS:	confirmed
Certificates:	UL

for two wires in one ferrule

## Packing sizes:

500 pcs.:	Part no.: 005694
10 x 100 pcs.:	Part no.: 005693
50000 pcs.:	Part no.: 005250

## Dimensions (mm):

l1	l2	d1	s1	d2	s2	d3
17	10	1.73	0.15	2.6	0.3	5.4

