

Wire end sleeve insulated twin 0.5 mm² - 8 mm A00555TWIN

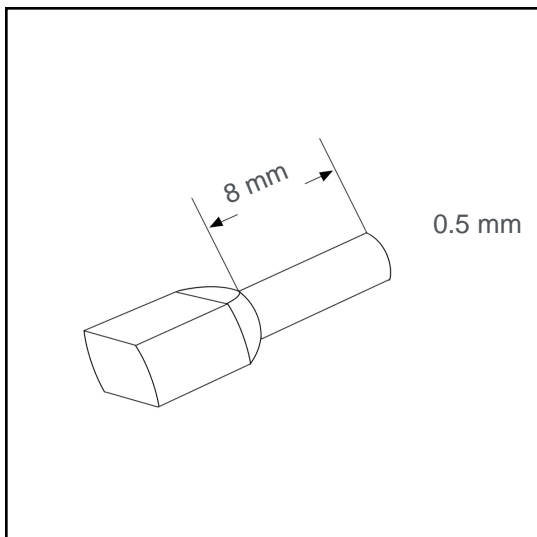

Datasheet:

Cross section (mm ²):	0.5
AWG:	2x20
Length (mm):	8
Color:	white
Material:	Cu-DHP / Polypropylene
Surface:	tin plated
Minimum thickness of tin coating:	3 μm
Max. Temp:	105°C
REACH/RoHS:	confirmed
Certificates:	UL

for two wires in one ferrule

Packing sizes:

500 pcs.:	Part no.: 005614
10 x 100 pcs.:	Part no.: 005613
50000 pcs.:	Part no.: 005047

Dimensions (mm):

l1	l2	d1	s1	d2	s2	d3
15	8	1.45	0.15	2.4	0.3	4.6

