

Wire end sleeve insulated 1.5 mm² - 10 mm A01575GB

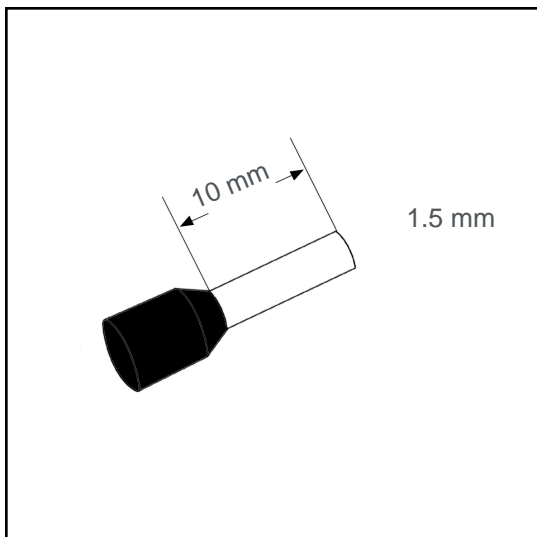

Datasheet:

Cross section (mm ²):	1.5
AWG:	16
Length (mm):	10
Color:	black
Material:	Cu-DHP / Polypropylene
Surface:	tin plated
Minimum thickness of tin coating:	3 μm
Max. Temp:	105°C
REACH/RoHS:	confirmed
Certificates:	UL

for wires with thick insulation (GB)

Packing sizes:

500 pcs.:	Part no.: 005792
10 x 100 pcs.:	Part no.: 005791
50000 pcs.:	Part no.: 005371

Dimensions (mm):

l1	l2	d1	s1	d2	s2
16	10	1.73	0.15	3.8	0.3

