

Wire end sleeve uninsulated 2.08 mm² - 10 mm B02010

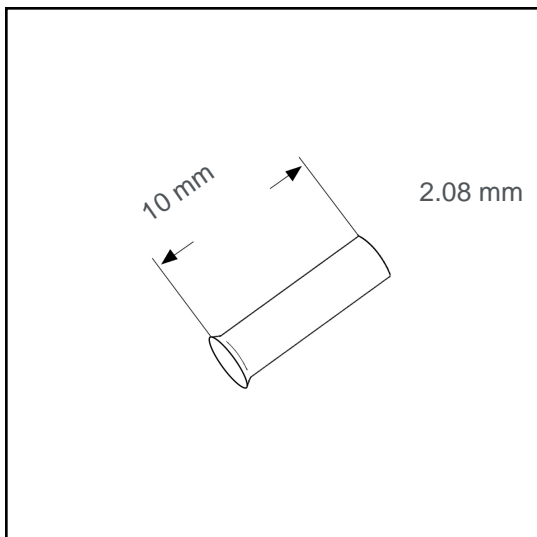

Datasheet:

Cross section (mm ²):	2.08
AWG:	16
Length (mm):	10
Material:	Cu-DHP
Surface:	tin plated
Minimum thickness of tin coating:	3 µm
Max. Temp:	105°C
REACH/RoHS:	confirmed

Packing sizes:

1000 pcs.:	Part no.: 006039
50000 pcs.:	Part no.: 005407

Dimensions (mm):

l1	d1	s1	d2
10	1.97	0.15	2.9

