

Wire end sleeve uninsulated 0.75 mm² - 12 mm B00712

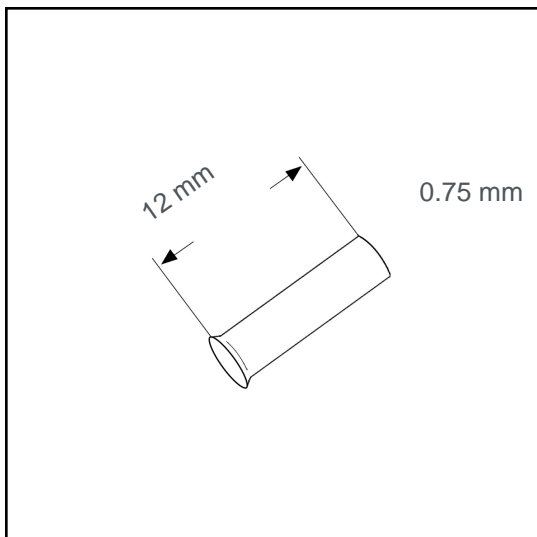

Datasheet:

Cross section (mm ²):	0.75
AWG:	18
Length (mm):	12
Material:	Cu-DHP
Surface:	tin plated
Minimum thickness of tin coating:	3 µm
Max. Temp:	105°C
REACH/RoHS:	confirmed

Packing sizes:

1000 pcs.:	Part no.: 006016
50000 pcs.:	Part no.: 005392

Dimensions (mm):

l1	d1	s1	d2
12	1.2	0.15	2.3

