

Aderendhülse isoliert 150 mm² - 32 mm

A150055

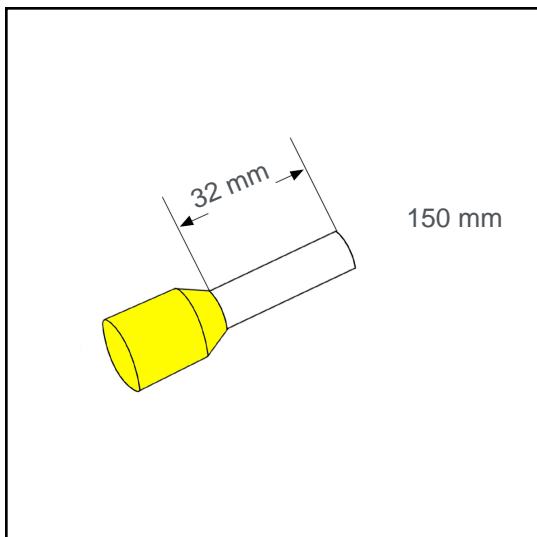

Technische Daten:

Leiterquerschnitt (mm ²):	150
AWG:	300MCM
Länge (mm):	32
Farbe:	gelb
Material:	Cu-DHP / Polypropylene
Oberfläche:	verzinnt
Mindestschichtdicke der Verzinnung:	3 µm
Max. Temp:	105°C
REACH/RoHS:	konform
DIN:	DIN 46228 T4

Verpackungseinheiten:

25 St.:	Art. Nr.: 005916
300 St.:	Art. Nr.: 005210

Abmessungen (mm):

l1	l2	d1	s1	d2	s2
58	32	18.6	0.5	22.6	1

